



Very economical **NEWBUILD** shallow-draft pusher tugs, 4 to 5 tonnes BP, fitted with double push-knee and towing hooks. Both conventional twin-prop and azimuthing stern drive (ASD) options available. These very compact and capable tugs can be tailored to your requirements with Tier III and Stage V certified engines, but also with fully electric drivetrains. Furthermore, they can be built under MCA, ES-TRIN or IACS rules.

General

Builder	Turkey
Built	2025 (NEW)
Classification	IACS, ES-TRIN, MCA
Notation	tba

Dimensions

LOA	12.87 m.
Beam	3.60 m.
Depth	2.00 m.
Draft	Approx. 1.30 m.

Machinery

Main engines	CONVENTIONAL ENGINE:
	Option A:
	2x Doosan type 4L066C
	2x 162 kW @ 1.800 rpm
	Option B:
	2x Doosan type 4L086C
	2x 235 kW @ 1.800 rpm
	Option C:
	2x Doosan type 4L126C
	2x 331 kW @ 1.800 rpm
	ZERO EMISSION:
	Option A:
	2x PM motor
	2x 159 kW @ 1.800 rpm
	option B:
	2x POD drive
	2x 200 kW @ 500 rpm
	Option C:
	2x POD drive
	2x 300 kW @ 500 rpm

Auxiliary Output	2x alternators, engine driven 80 A.
Propulsion	Option A: 2x Fixed-pitch props, 780 mm diam.
	Option B: 2x Olympiac azimuthing drive HD3, 686 mm FP with nozzle (360 deg. in 3 seconds)

Performance

Speed	12 knots
Bollard pull	4 - 10 t. (depending on propulsion choice)

Deck equipment

Towing hook	Optional, disc-type, 7 tons SWL
Fwd coupling winch	24 V electric driven (requires additional alternators and batteries)
Aft coupling winch	24 V electric driven (requires additional alternators and batteries)
Towing bitt	Single pole
Fendering	Rubber D-fender
Push bow	Double cylindrical rubber fender

Tank capacities

Fuel oil	5.5 m ³
Fresh water	0.5 m ³
Sewage	0.8 m ³
Bilge water	0.5 m ³

Communication equipment (optional)

Standard	Searchlight, navigation lights, VHF, compass
Optional	Marine radar, GPS, Echosounder, GMDSS A1, AIS etc.

Accommodation

The wheelhouse and below-deck area are well-insulated and finished with modern, sturdy linings. The floor is made of durable rubber or synthetic material. The wheelhouse has a bench for two, a table, a washbasin, and a helmsman seat. Below deck, there's a toilet and lockers.



Azimuthing drive:

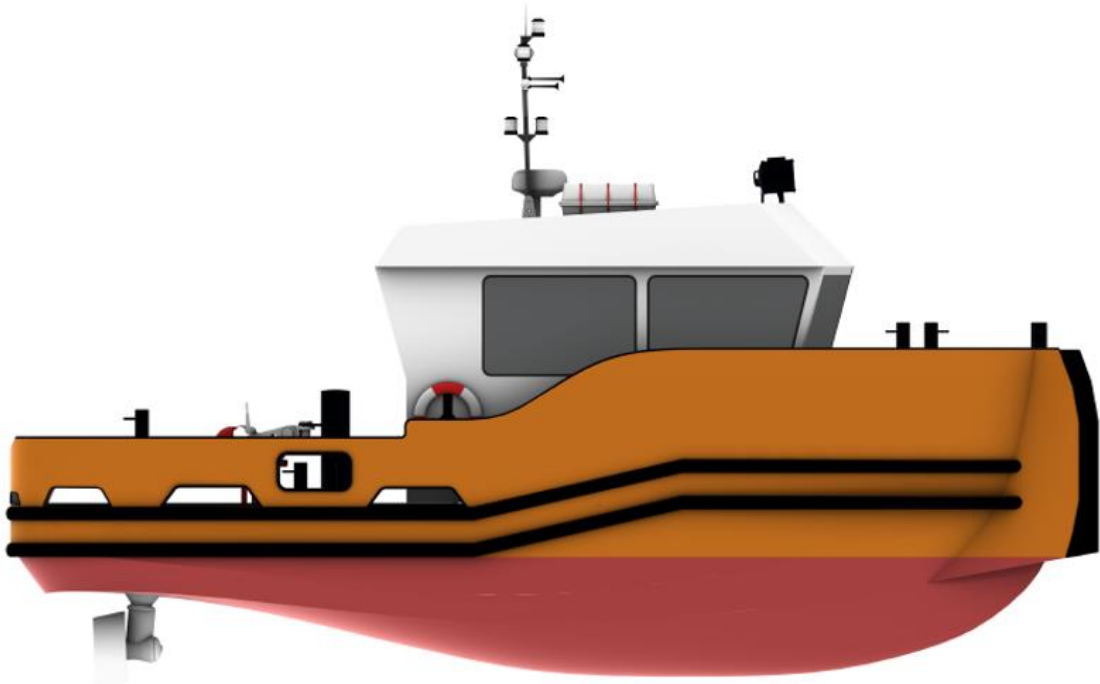
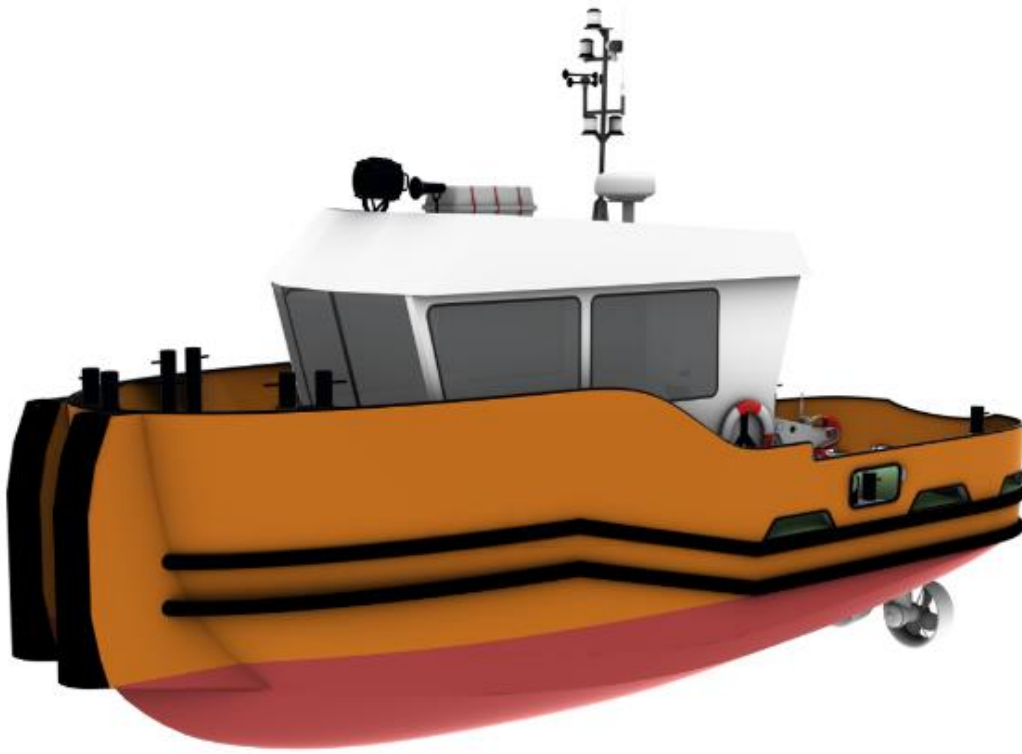

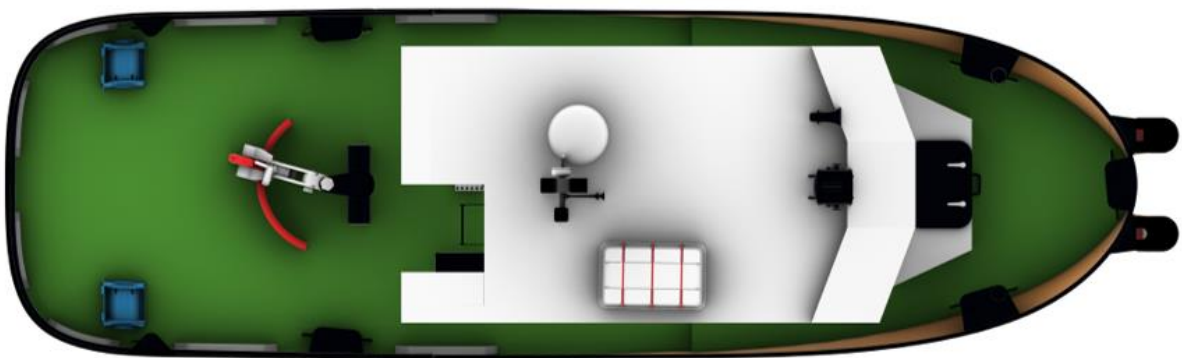

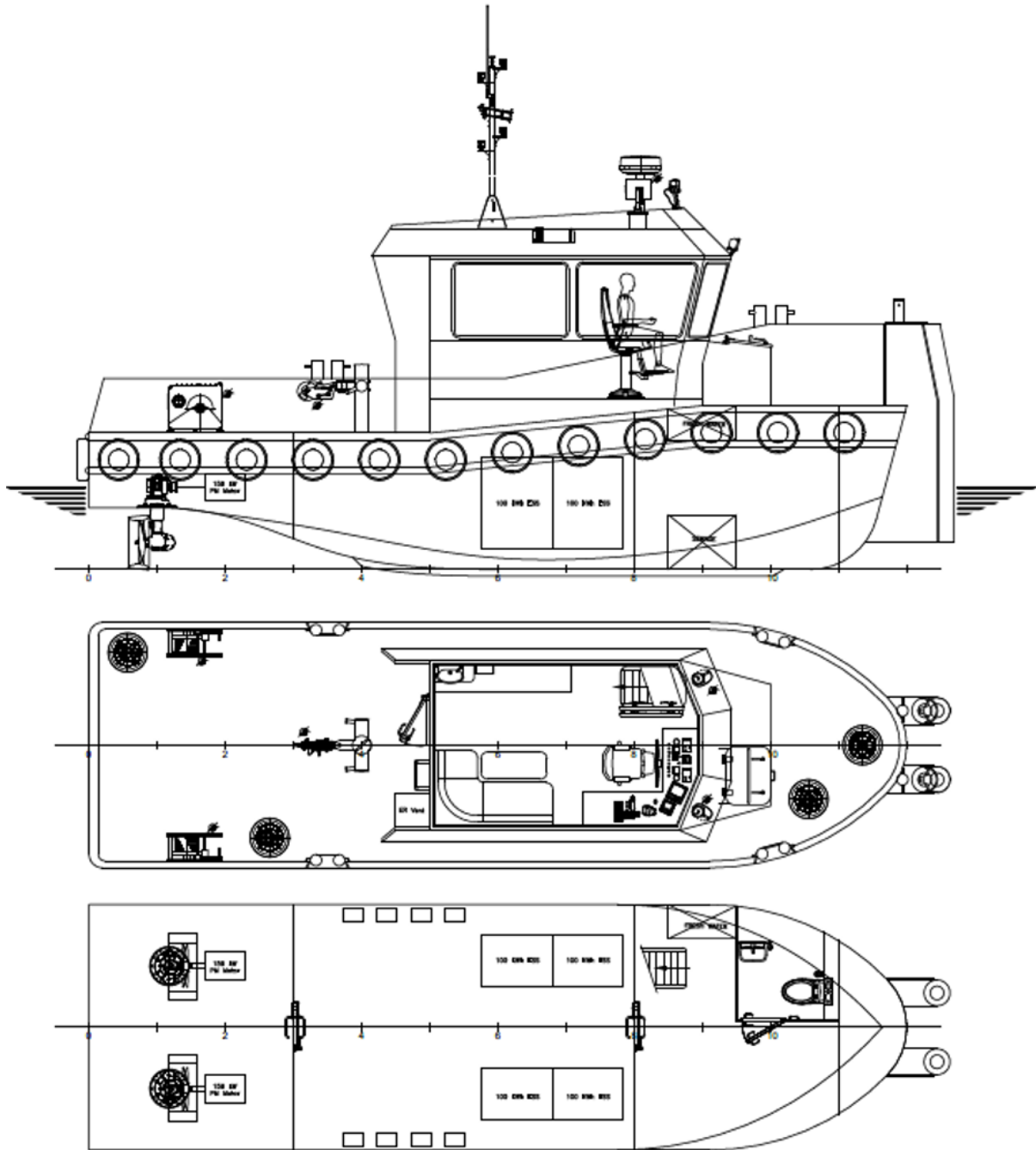



Conventional drive:

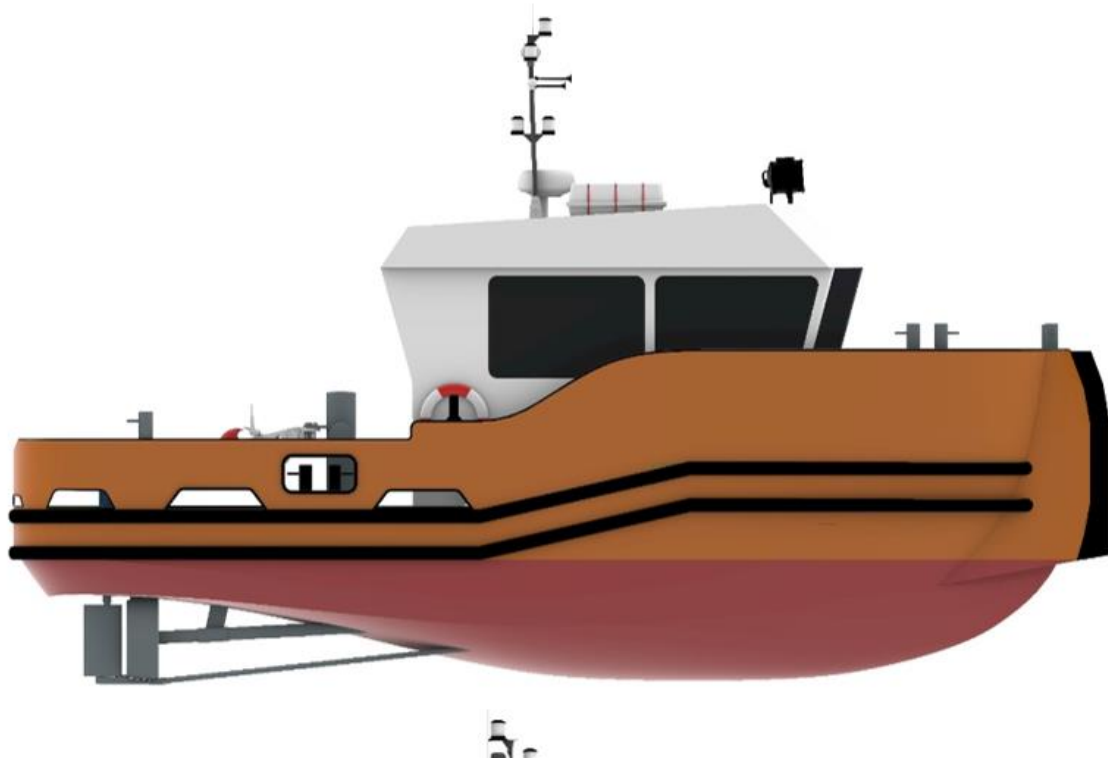



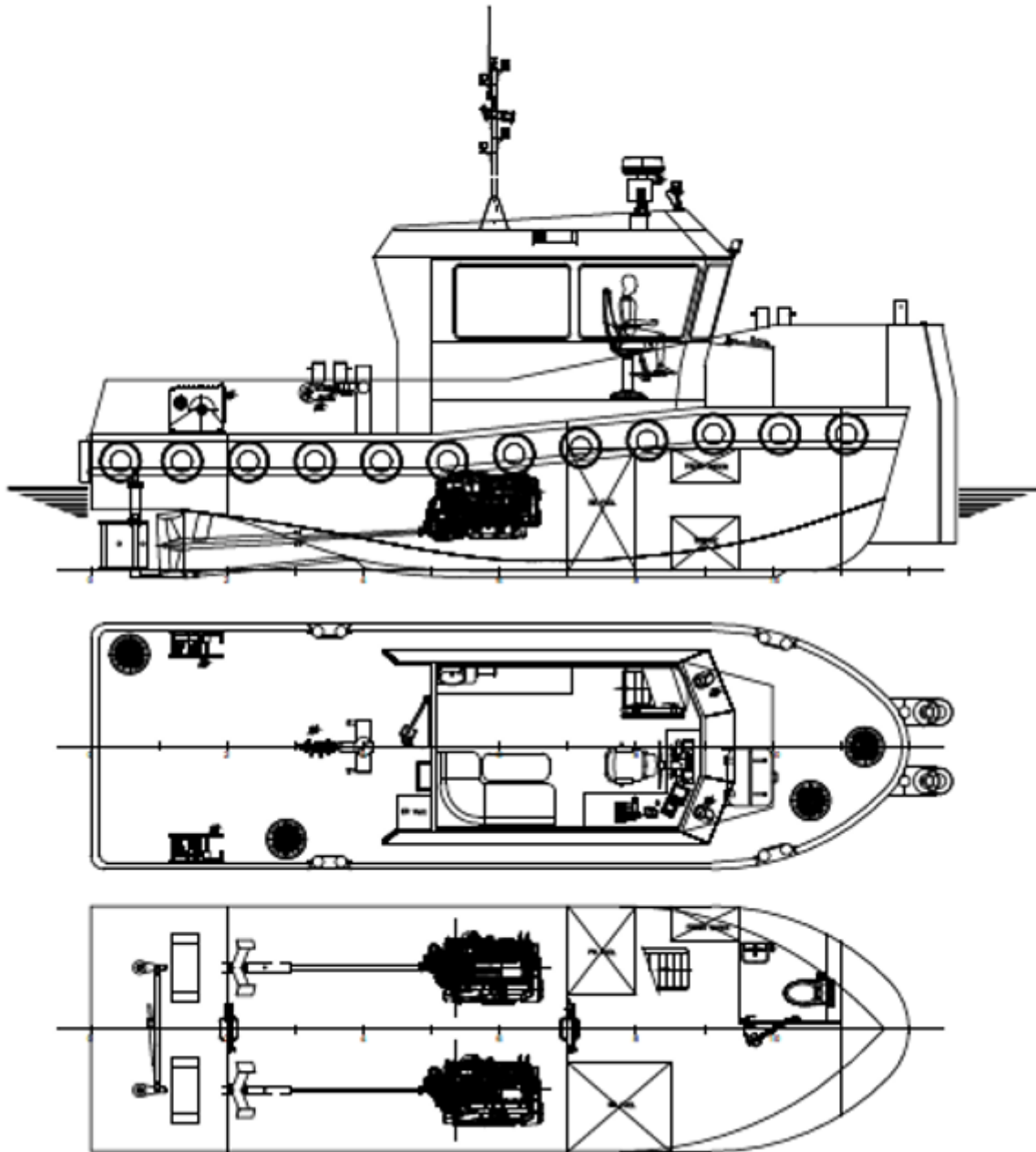



E-DRIVE

